

British Biology Olympiad

Sample paper



1. All of the following are factors influencing membrane fluidity except which one?

- A. Number of double bonds in the lipids
- B. Temperature
- C. Flip-flop movement of lipids
- D. Cholesterol
- E. Proteins

2. Which of the following statements, or combinations of statements, is correct about the synthesis of proteins?

- 1. *Protein synthesis only takes place by ribosomes bound to the endoplasmic reticulum.*
- 2. *tRNA molecules transport amino acids to ribosomes during protein synthesis.*
- 3. *A codon can code for more than one amino acid.*

- A. 1 only.
- B. 2 only.
- C. 3 only.
- D. 1 and 2 only.
- E. 2 and 3 only

3. The best explanation for the statement that 'ATP is better than either glucose or fatty acids as an energy source for cell metabolism' is:

- A. energy is released rapidly
- B. more energy is released
- C. there is no requirement for ATP to undergo respiration
- D. energy is released in small manageable quantities
- E. energy is released continuously

4. The endoplasmic reticulum is an extension of which membrane?

- A. Outer cell membrane / unit membrane
- B. Outer nuclear membrane
- C. Inner nuclear membrane
- D. Vesicular membrane
- E. Tonoplast

5. A bacterial cell wall performs all of the following functions except

- A. giving shape and rigidity to the cell
- B. being the site of action for some antibiotics
- C. being associated with some symptoms of disease
- D. protecting the cell from phagocytosis
- E. helping identify the type of bacterium

6. How does cyanide (CN) cause the death of living things?

- A. By stopping photosynthesis
- B. By breaking down protein molecules
- C. By stopping oxidation
- D. By stopping the electron flow through the Electron Transport Chain
- E. By stopping utilisation of energy reserves

7. Which combination of the following statements about the properties of organelles is correct?

- 1. *Mitochondria contain their own DNA*
- 2. *Lysosomes contain many types of enzyme*
- 3. *Hepatocytes have well developed Golgi apparatus*
- 4. *Ribosomes are always attached to the RER*

- A. 1, 2 and 3
- B. 2, 3 and 4
- C. 1, 2 and 4
- D. 1, 3 and 4
- E. all of them

8. All the molecules below, except one, are involved in either the Krebs Cycle or the Electron Transport Chain in aerobic respiration. Which is the odd one out?

- A. NADH
- B. FADH₂
- C. NADPH
- D. ATP synthase
- E. Cytochrome oxidase

9. Which of the following combinations of statements is correct?

1. *Most cells are capable of phagocytosis.*
2. *Phagocytosis involves uptake of larger particles than pinocytosis.*
3. *In any given time period the volume of endocytosed matter is about twice that of exocytosed matter.*
4. *Pinocytosis uptakes molecules selectively according to the needs of the cell.*
5. *Receptor-mediated endocytosis can be an entry point for viruses.*

- A. 1 and 4
- B. 2 and 5
- C. 1, 3 and 5
- D. 2, 3 and 4,
- E. all of them

10. The following statements about the structure of DNA are all true except which one?

- A. There are always equal amounts of guanine and cytosine nucleotides
- B. Purine bases pair with pyrimidine bases
- C. Uracil pairs with adenine
- D. Phosphodiester bonds link adjacent nucleotides
- E. Hydrogen bonds are the major forces that maintain a double helix structure

11. The manufacture of bread, beer and wine all involve alcoholic fermentation of glucose to ethanol by yeast. Which combination of the following five statements concerning this process is correct?

1. *Yeast carries out this fermentation because yeast cells lack mitochondria*
2. *For every molecule of ethanol produced, one molecule of CO₂ is evolved*
3. *The net generation of ATP is only two molecules per molecule of glucose fermented*
4. *More than 80% of the chemical energy of the glucose is released as heat*
5. *Glycolysis is an integral part of this fermentation*

- A. 1, 2 and 3
- B. 1, 2 and 4
- C. 2, 3 and 5
- D. 2, 4 and 5
- E. 3, 4 and 5

12. If one could suddenly remove all the protein molecules from the plasma membrane of a cell (without destroying the cell), which of the following would one expect to happen?

- A. Transport of all molecules across the plasma membrane would stop.
- B. Transport of most ions across the plasma membrane would stop.
- C. The amount of cholesterol in the plasma membrane would decrease.
- D. Amino acids would rapidly aggregate on the plasma membrane and replace the missing proteins.
- E. Large macromolecules would diffuse out of the cell.

13. The antibiotic erythromycin works by blocking the movement of the ribosome along prokaryotic mRNA. If erythromycin is administered, which of the following immediate effects would be expected in a bacterial cell?

- A. Inhibition of transcription of DNA to RNA
- B. Inhibition of translation of RNA to protein
- C. Inhibition of DNA replication
- D. Inhibition of rRNA transcription only
- E. Inhibition of amino acid synthesis

14. Which of the following is a "reduction" reaction?

- A. $\text{Na} + \text{H}_2\text{O} \rightarrow \text{Na}^+ + \text{HO}^- + \frac{1}{2}\text{H}_2$
- B. $\text{H}_2 \rightarrow 2\text{H}^+ + 2\text{e}^-$
- C. $\text{CH}_4 + \text{O}_2 \rightarrow \text{CH}_2\text{O} + \text{H}_2\text{O}$
- D. $2\text{H}_2 + \text{O}_2 \rightarrow 2\text{H}_2\text{O}$
- E. $\text{Cl}_2 + 2\text{e}^- \rightarrow 2\text{Cl}^-$

15. When a cell shows incipient plasmolysis:

- A. the water potential will be at its least negative value
- B. the pressure potential will be zero
- C. the solute potential will be high and positive
- D. the solute potential will be high and negative
- E. the pressure potential will be high

16. The sections of a gene that do not code for protein are:

- A. codons
- B. clones
- C. exons
- D. introns
- E. primers

17. Which of the following processes absorb free energy (i.e is/are endergonic)?

1. *Nitrogen fixation*
2. *Respiration*
3. *Photosynthesis*
4. *Achieving homeostasis*

- A. 1 only
- B. 1 and 2
- C. 1, 3 and 4
- D. 1 and 4
- E. 3 and 4

18. On which one of the following features of nucleic acids does protein synthesis in the cell ultimately depend?

- A. DNA is in the form of a double helix
- B. The bases of DNA are in a specific sequence
- C. That the hydrogen bonds between the bases are weak
- D. Messenger RNA is a single strand
- E. DNA is self replicating

19. An electron microscope (resolution 1nm) can visualize structures smaller than 100 nanometres. Which structures could you only see with the aid of an electron microscope?

1. *A frog egg*
2. *A plant chloroplast*
3. *A virus particle*
4. *A protein molecule*
5. *Most bacteria*

- A. 1, 2 and 5
- B. 2 and 3
- C. 3 and 4
- D. 3 and 5
- E. 4 only

20. Which feature is possessed by angiospermophytes but not by coniferophytes?

- A. Leaves
- B. Seeds
- C. Xylem
- D. Flowers
- E. Stomata

21. Tropic curvature in a root is due to:

- A. gravity destroying auxin
- B. movement of auxin in different amounts into each side of the region of growth
- C. production of auxin in different amounts down each side of the region of growth
- D. induction of different responses on each side of the root although the auxin is distributed evenly.
- E. destruction of auxin on the concave side of the region of growth

22. Which of the following effects is brought about by both gibberellic acid and indole acetic acid?

- A. Induction of alpha amylase in seed grains
- B. Promotion of cell elongation
- C. Breaking of dormancy in seeds
- D. Reversal of genetic dwarfism
- E. Inhibition of growth of side shoots

23. Horchata is a cold, milky drink, common in Spain. It is made from the tubers of a sedge-like plant called Chufa. Tubers are:

- A. enlarged ends of rhizomes or stolons specialised for storing food
- B. enlarged roots that store nutrients over winter
- C. specialised root structures found underground
- D. another term for bulbs
- E. specialised, swollen stems

24. Which of the following plant hormones or class of plant hormones is mostly synthesized in the apical (stem) meristems of plants?

- A. Ethylene.
- B. Abscisic acid.
- C. Gibberellin.
- D. Cytokinin.
- E. Auxin.

25. Which one of the following structures provides a pollen grain with nourishment during its development in the pollen sac?

- A. Endosperm
- B. Nucellus
- C. Placenta
- D. Stomium
- E. Tapetum

26. Dichlorophenol indophenol (DCPIP) is a blue dye that is decolorized when reduced. After being mixed with DCPIP which one of the following would show the greatest change in colour?

- A. Isolated chloroplasts in the dark;
- B. Isolated chloroplasts in the light;
- C. Chlorophyll extract in the dark;
- D. Boiled chloroplasts in the dark;
- E. Boiled chloroplasts in the light.

27. In angiosperms the pigment involved in detecting day length is:

- A. carotene
- B. chlorophyll
- C. cytochrome
- D. phytochrome
- E. auxin

28. In photosynthesis in a C4 plant:

- A. CO₂ is accepted by the substrate RuBP and is fixed as PGA
- B. CO₂ is accepted by the substrate RuBP and is fixed as oxaloacetic acid
- C. CO₂ is accepted by the substrate PEP and fixed as PGA
- D. CO₂ is accepted by the substrate PEP and fixed as oxaloacetic acid
- E. CO₂ is accepted by the substrate PEP and fixed as RuBP

29. Tissues that form long, tough strands, as in the leaf stalk of celery, are:

- A. epidermis
- B. collenchyma
- C. sclerenchyma
- D. parenchyma
- E. phloem

30. Ferns have:

- A. leaves, stems and roots but no flowers or seeds
- B. leaves and roots but no stems, flowers or seeds
- C. leaves, stems, roots and seed but no flowers
- D. leaves but no stems, roots, seeds, or flowers
- E. stems, roots but no flowers or seeds and no leaves

31. When spores from ferns fall onto damp ground, they can develop into small heart-shaped structures which will contain:

- A. the male reproductive organs
- B. the female reproductive organs
- C. no reproductive organs as this is the asexual stage
- D. both male and female reproductive organs
- E. the sporophyte generation

32. The major barrier to filtration of fluid into Bowman's capsule is provided by the:

- A. podocytes
- B. capillary endothelium
- C. pores
- D. basement membrane
- E. red blood cells

33. Stimulation of the vagus nerve to the heart would:

- A. increase the output of blood
- B. increase the rate of heart contraction
- C. decrease the rate of heart contraction
- D. decrease the blood pressure
- E. stimulate atrial systole

34. The gills of a salt water fish:

- A. lose water by osmosis and absorb salts
- B. gain water by osmosis and absorb salts
- C. lose water by osmosis and excrete salts
- D. gain water by osmosis and excrete salts
- E. only excrete salts

35. Which of the following combinations of statements about muscle is correct?

1. *Thick filaments are formed mainly from myosin.*
2. *Thin filaments are formed mainly from actin.*
3. *The H zone is formed by thick filaments alone.*
4. *The Z band lies in the centre of the I band.*
5. *Actin holds actin filaments to the Z disc.*

- A. all of them
- B. 2, 3, 4 and 5
- C. 3, 4 and 5
- D. 2, 3 and 5
- E. 1, 2 and 3

36. Myocytes are cells that can beat independently, outside the body, if supplied with glucose and oxygen. Myocytes are cells from:

- A. muscle
- B. heart
- C. brain
- D. protists
- E. artery walls

37. Cyanide ions in very low concentrations might be expected to affect nerve axon activity by:

- A. lowering the sodium pump activity
- B. preventing the movement of the wave of depolarisation
- C. preventing saltation
- D. changing the permeability of the axon membrane
- E. depressing acetylcholine activity

38. Which one of the following statements about liver function is incorrect?

- A. Synthesises cholesterol from acetyl Co A
- B. Carries out gluconeogenesis
- C. Metabolises amino acids, fats and carbohydrates
- D. Stores bile, important in emulsifying fats in digestion
- E. Manufactures heparin and plasma proteins

39. Which one of the statements below about the mammalian nervous system is correct?

- A. Sensory nerve impulses enter the spinal cord by the dorsal root
- B. Sensory nerve impulses enter the spinal cord by the ventral root
- C. Motor nerve impulses enter the spinal cord by the dorsal root
- D. Motor nerve impulses enter the spinal cord by the ventral root
- E. Motor nerve impulses leave the spinal cord by the dorsal root

40. Which of the following are typical features of a neutrophil?

- 1. *It is agranulocytic*
- 2. *Engulfs bacteria by phagocytosis*
- 3. *Is the most abundant white blood cell*
- 4. *Is the smallest white blood cell*
- 5. *Has a compact round nucleus*

- A. 1, 2 and 3
- B. 1, 2, 3 and 5
- C. 2 and 3
- D. 2, 3 and 4
- E. All of the above

41. The main component of blood plasma is:

- A. Ca^{2+}
- B. CO_2
- C. O_2
- D. Urea
- E. Water

42. A B-lymphocyte produces and secretes antibodies. Which structure(s) of its protoplast should therefore be well-developed ?

- A. only the smooth endoplasmic reticulum
- B. only the smooth endoplasmic reticulum and the Golgi apparatus
- C. only the rough endoplasmic reticulum
- D. only the rough endoplasmic reticulum and the Golgi apparatus
- E. the rough endoplasmic reticulum, the Golgi apparatus and the lysosomes

43. Which of the following changes has taken place when a person has become acclimatised to high altitudes?

- A. Heart rate has increased
- B. Lung capacity has increased
- C. Oxygen carrying capacity of the blood has increased
- D. The blood volume has increased
- E. Ventilation rate has increased

44. Some metals have been linked to various neurological diseases, including Parkinson's disease and Alzheimer's disease. Which metals have been most linked to these two diseases?

	Parkinson's Disease	Alzheimer's Disease
A	Lead	Aluminium
B	Iron	Copper
C	Copper	Iron
D	Aluminium	Iron
E	Iron	Aluminium

45. Which of the following would cause the kidneys to reabsorb more water?

- A. Increased blood volume
- B. Increased cardiac output
- C. Decreased blood pressure
- D. Decreased anti-diuretic hormone (ADH) concentration
- E. Decreased aldosterone levels

46. All of the following statements about a nerve impulse are true, except which one?

- A. The magnitude of an impulse is always the same
- B. After one impulse there is a refractory period when the axon cannot be restimulated
- C. A nerve impulse can pass along an axon in one direction only
- D. It has a threshold below which it cannot be stimulated
- E. The resting potential of an axon is - 70mV

47. Which animal would produce a nitrogenous waste product with the lowest solubility in water?

- A. Butterfly
- B. Shark
- C. Frog
- D. Polar bear
- E. Freshwater fish

48. Which one of the following is an example of a negative feedback system?

- A. The more you scratch, the more it itches, so the more you scratch.
- B. As blood sugar levels increase, insulin is released, signalling cells to take up sugar.
- C. During childbirth, the pressure of the baby's head on the cervix causes the release of a hormone signal that increases the strength of contraction in the birth canal.
- D. Pressure on the car brake during a quick stop causes forward momentum on the driver, causing an increase in pressure on the brake.
- E. Application of a depolarizing drug to a neuron brings the membrane to threshold potential which opens voltage-gated Na⁺ channels

49. In the mammalian kidney, what causes water to be reabsorbed in the descending limb of the loop of Henle?

- A. Active transport of salt out of the tubule.
- B. An increase in the osmolarity of the nephron fluid (filtrate).
- C. Diffusion of salt out of the tubule.
- D. High blood pressure.
- E. Secretion of hydrogen ions from the renal medulla into the tubule.

50. In the mammalian circulatory system, excess fluid remaining in tissue spaces (interstitial fluid) is:

- A. used to form urine.
- B. removed in the form of sweat.
- C. drained away by the lymphatic system.
- D. reabsorbed back into the capillary bed.
- E. absorbed by fat cells.

51. When you listen to a human heartbeat through a stethoscope, the softer “lubb” of the “lubb-dub” sound the heart makes is caused by which of the following actions?

- A. Closing of the atrioventricular valves (mitral and tricuspid).
- B. Closing of the semilunar valves (aortic and pulmonary).
- C. Sound of blood rushing into the atria.
- D. Sound of blood rushing into the ventricles.
- E. Sound of blood rushing into the aorta.

52. Why is a new strain of avian (bird) influenza that can cause serious illness in humans a concern to governments around the world?

1. *The bacterium that causes bird flu is resistant to most antibiotics.*
2. *The organism that causes bird flu may mutate so that it can spread from human to human.*
3. *The organism that causes bird flu is carried by wild birds and can be spread around the world as birds migrate.*
4. *The organism that causes bird flu can be spread by eating cooked chicken.*
5. *Vaccines will not work against the type of organism that causes bird flu.*

- A. 1, 2, 3, 4 and 5
- B. 1 and 5
- C. 2 and 3
- D. 2, 3 and 4
- E. 4 and 5

53. A patient has symptoms of gigantism. After a series of tests, it is concluded that the patient most likely has a tumour on which of the following structures?

- A. Pituitary gland
- B. Adrenal gland
- C. Thyroid gland
- D. Hypothalamus
- E. Parathyroid gland

54. When a current of water from a capillary tube is directed against the disc of the large protozoan Stentor, the animal at first contracts but soon expands again. The next time, it does not react to the current but continues normal activities immediately. This behaviour pattern is an example of:

- A. classical conditioning
- B. operant conditioning
- C. latent learning
- D. reflex learning
- E. habituation (negative conditioning)

55. Eating of night faeces is a common feature in the rabbit. Which statement best describes the biological advantage of this habit?

- A. It ensures that products of digestion which enter the colon can be absorbed.
- B. Water is conserved in an animal that does not drink much water.
- C. It overcomes the problem of a short ileum.
- D. Nocturnal predators such as foxes will be unable to detect their prey.
- E. It ensures that assimilation is complete.

56. The prime effect of territorial behaviour in social mammals is usually to:

- A. disperse the members of a population.
- B. promote the economic use of available food.
- C. division of labour.
- D. prevent interbreeding with other groups.
- E. promote the establishment of a hierarchy.

57. Animal behaviour patterns, in which an individual endangers its life to benefit other members of the group, are called altruistic. It is believed that altruistic behaviour is favoured by kin selection. Which of the following examples given below cannot be explained as kin-selection ?

- A. Suicidal attack by a worker bee guarding its hive
- B. Protection of the queen of an ant species by "soldier" ants
- C. Protection of lion cubs by a lioness NOT being their mother
- D. Warning cries of a bird warning other individuals about approaching danger
- E. In fact, all of the above behaviour patterns probably arose through kin selection

58. Researchers have shown that young female black grouse mate preferentially with males that have mated with other females. Which of the following is not a testable hypothesis for the ultimate causation of this behaviour?

- A. Copying other females speeds mate selection and reduces potential exposure to predators
- B. Imitation helps younger females learn to recognize male traits that may increase fitness
- C. Copying other females speeds mate selection and increases the fitness of young females
- D. Selected males occupy a location near the centre of the lek (display & courtship area)
- E. Mate selection in black grouse is determined by a combination of genetic and environmental factors

59. The pedigree chart below shows the blood groups of two children and their mother. What could be the blood group of the father?

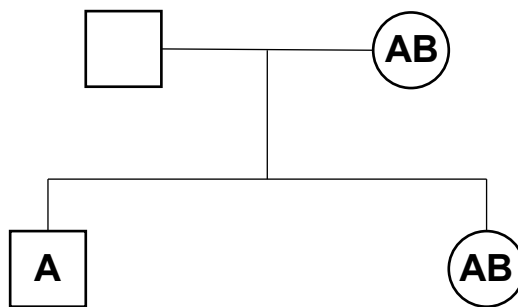

- A. A only
- B. A or B
- C. A or AB
- D. A, B or AB
- E. A, B, AB or O

60. A diploid cell contains the alleles R and r on one pair of homologous chromosomes and the alleles S and s on another pair of homologous chromosomes. How many combinations of these alleles could appear in the gametes after meiosis?

- A. 1
- B. 2
- C. 4
- D. 8
- E. 16

61. Two morphologically distinct types of moth *Biston betularia* are found. The speckled type (*typica*) and the pigmented mutant type (*carbonaria*). In industrial areas *carbonaria* is most abundant whilst in rural areas *typica* is more abundant. Which one of the following least satisfactorily explains this distribution?

- A. Industrial pollution increases the frequency of mutation
- B. *Carbonaria* has a greater survival rate in industrially polluted area
- C. Changes in the habitat caused by industrial pollution cause selection against *typica*
- D. Predation by birds affects distribution of the two types
- E. Changes in the habitat caused by industrial pollution increase the predation on *typica*

62. When using the capture-recapture technique to estimate the size of an animal population, which of the following would lead to the size estimated being an underestimate of the population?

1. *a higher predation of marked than of unmarked animals*
2. *a greater attraction of marked than of unmarked to the traps*
3. *emigration of unmarked animals between samplings*
4. *an immigration of animals into the area between samplings*
5. *a higher but proportionally equal mortality of both marked and unmarked animals*

- A. 1 and 2
- B. 1 and 3
- C. 2 and 3
- D. 1 and 5
- E. All of them

63. Which statements concerning inbreeding are correct?

1. *Inbreeding increases the chance of individuals arising that are double recessive for an unfavourable allele*
2. *Inbreeding results in loss of genetic diversity amongst individuals of a domestic variety*
3. *Inbreeding depression results from hybridisation between unrelated species*
4. *Inbreeding promotes the retention of favourable characteristics*
5. *Inbreeding increases the chance of unfavourable characteristics*

- A. 1, 2, 3 and 4
- B. 1, 2, 4 and 5
- C. 1, 2, 3
- D. 1, 3, 4 and 5
- E. 1, 4 and 5

64. Which statements about genetic disorders in humans are correct?

1. *The frequency of the allele for sickle cell anaemia is higher in native populations of wet, tropical countries because carriers have a better chance of surviving malaria.*
2. *Colour blindness is rare in females because the condition is recessively inherited and the gene is sex linked.*
3. *Down syndrome occurs when three copies of chromosome 21 are present.*
4. *Aneuploidies, such as Down syndrome, results from errors in DNA replication during the S phase.*
5. *Sperm containing a Y chromosome fertilizing an ovum (egg) that contains no sex chromosome results in a spontaneous abortion.*

- A. 1, 2, 3 and 4
- B. 1, 2, 4 and 5
- C. 1, 2, 3 and 5
- D. 1, 3, 4 and 5
- E. 2, 3, 4 and 5

65. In pheasant, males are larger and have more colourful plumage than females. Which of the following is most likely to account for these differences between males and females?

- A. Natural selection
- B. Risk of predation
- C. Mimicry
- D. Sexual selection
- E. Niche differences between the sexes

66. Which of the following best describes the “flippers” found in seals, sharks, and penguins?

- A. Homologous structures resulting from divergent evolution.
- B. Analogous structures resulting from divergent evolution.
- C. Homologous structures resulting from convergent evolution.
- D. Analogous structures resulting from convergent evolution.
- E. Homologous structures representing a monophyletic grouping.

67. Which one of the following is an example of divergent evolution?

- A. Eyes of locusts and blackbirds
- B. Skeletons of tortoises and lobsters
- C. Wings of cockroaches and bats
- D. Wings of cockroaches and birds
- E. Forelimbs of pigeons and Dolphins

68. In carnations, genes that code for flower colour show an incomplete dominance relationship. Red flowers crossed with white flowers yield pink flowers. What is the expected distribution of progeny from a cross between a pink-flowered parent and a red-flowered parent?

- A. 1:1 ratio of red to pink
- B. All red
- C. All pink
- D. 1:1 ratio of red to white
- E. 1:2:1 ratio of red to pink to white

69. A drug company developed a new insecticide that is highly poisonous to mosquitoes carrying West Nile virus. Mass spraying of the insecticide over a 10 year period resulted in a significant reduction in mosquito populations over the first five years, and a gradual increase in mosquito populations over the next five years. What is the most reasonable explanation for the observed effect of the insecticide on mosquito populations?

- A. The insecticide caused favourable mutations in the mosquitoes that led to resistance.
- B. Genetic variants of mosquitoes resistant to the insecticide survived and transmitted their resistance to their offspring.
- C. Mosquitoes from other populations in other areas moved in and replaced the mosquitoes killed by the insecticide.
- D. The insecticide induced antibodies to the insecticide in some mosquitoes and these antibodies were then transmitted to offspring.
- E. The drug company reduced the amount of insecticide sprayed in the environment.

70. In the fruit fly *Drosophila melanogaster*, the white-eye allele is X-linked and recessive. What would be the outcome of a cross between a white-eyed female and a red-eyed male?

- A. The result would depend on the genotype of the parents.
- B. All females will be red-eyed and all males will be white-eyed.
- C. All males will be white-eyed and females will have a 1:1 red-eye to white-eye distribution.
- D. Any combination of sex and eye colour is possible.
- E. Female to male distributions and red-eye to white-eye distributions will be 1:1, independent of one another.

71. Of which of the following phenomena do Darwin's observations of the Galapagos finches provide a classic example?

- A. Flightlessness
- B. Convergent evolution
- C. Adaptive radiation
- D. Sympatric speciation
- E. Hardy-Weinberg equilibrium

72. The main advantage of sexual reproduction compared with asexual reproduction is that it enables:

- A. interspecific hybridisation to take place
- B. recessive characters to appear in the phenotype of the offspring
- C. evolution to occur
- D. genes to be re-assorted independently
- E. genetic variation to be maintained

73. Consider three independently-assorting genes in humans: A, B and C. What is the probability that a mother of genotype AaBBCc and a father of genotype AAbbCc will produce a child of genotype AABbcc?

- A. $1/2$
- B. $1/4$
- C. $1/8$
- D. $1/16$
- E. $1/64$

74. Which of the following statements about sexual reproduction is correct?

- A. Spores are produced by the fusion of two haploid gametes.
- B. Progeny are genetically identical to their parents.
- C. Diploid gametes are produced by mitosis.
- D. Fertilisation results in the formation of a diploid zygote.
- E. Both male and female gametes are diploid.

75. Which of the following combinations of statements about an autosomal dominant gene is correct?

- 1. *It will exhibit a phenotype in heterozygotes*
- 2. *It will be transmitted to all progeny from a homozygous parent*
- 3. *It cannot be carried on the Y chromosome*
- 4. *It cannot be transmitted from males to males*

- A. 1, 2, 3 and 4
- B. 1, 2 and 3
- C. 2, 3 and 4
- D. 1, 3 and 4
- E. 1 and 2 only

76. When dihybrid plants of *Capsella* (Shepherd's purse) were inter-pollinated, 94% of the progeny possessed triangular seed capsules and 6% ovoid seed capsules. What is the genotype of a plant with ovoid seed capsules?

- A. AaBb
- B. AaBB
- C. Aabb
- D. aabb
- E. aaBB

77. Slash and burn is a system of agriculture used in tropical rainforests. A small area of forest is cleared of trees and cultivated for 2 or 3 years. It is then left to recover over many years, while other areas are cultivated. The method of agriculture is NOT suitable for cultivation of large areas of rainforest. Which of the following is the best reason for this?

- A. The land is exposed to erosion and minerals are leached from the soil
- B. Reduced amounts of carbon dioxide are removed from the atmosphere
- C. Carbon dioxide is added to the atmosphere in combustion
- D. Reduction of habitats for various organisms
- E. There will be less humus in the soil

78. In a lake, the ratio of productivity of phytoplankton to productivity of zooplankton per year was calculated to be 9.5 : 1. How is this figure consistent with the principles of energy transfer through an ecosystem?

- A. Zooplankton are small animals that feed on phytoplankton.
- B. Approximately 10% of energy passes from phytoplankton to zooplankton.
- C. Approximately 90% of energy passes from phytoplankton to zooplankton.
- D. Energy is lost at each stage of transfer in a food chain.
- E. The energy is used by zooplankton for respiration and growth.

79. Competition between members of different species is called:

- A. interspecific, and is normally less intense than intraspecific competition
- B. interspecific, and is normally more intense than intraspecific competition
- C. intraspecific, and is normally less intense than interspecific competition
- D. intraspecific, and is normally more intense than interspecific competition
- E. intraspecific, and is normally about the same as interspecific competition

80. The increase in the Index of Diversity is one indication that a biological succession is taking place in an area. Which of the following are features of succession that would bring about an increase in the Index of Diversity?

1. *Initial hostile environment*
2. *More niches or habitats*
3. *Increase in available humus content in the soil*
4. *Increase in minerals in the soil*
5. *A stable environment*
6. *Grazing by animals*

- A. 1, 2, 3, 4, and 5
- B. 1, 3, 4, 5 and 6
- C. 2, 3, 4 and 5
- D. 2, 4, 5 and 6
- E. 1, 2, 3 and 4

81. In a food chain isolated from others, which of the following (measured in kJ m^{-2}) is numerically the greatest?

- A. Net primary production in plants
- B. First carnivore consumption
- C. Herbivore assimilation
- D. Herbivore respiration
- E. Plant biomass increase.

82. Which of the following processes occur during the nitrogen cycle?

1. *The oxidation of nitrites to nitrates by root nodule bacteria.*
2. *Consumption of plant protein by herbivores.*
3. *The conversion of dead organisms into ammonia by decomposers.*
4. *Conversion of ammonium compounds into nitrates by denitrifying bacteria.*
5. *The oxidation of ammonium compounds into nitrites by nitrifying bacteria.*

- A. 1 and 2
- B. 2 and 3
- C. 3 and 4
- D. 1, 2 and 3
- E. 2, 3 and 5

83. Various terms are used to describe areas or regions where organisms are found. Which of the following lists shows these regions in order of decreasing size?

- A. territory – ecosystem – biosphere – habitat
- B. biosphere – ecosystem – habitat – territory
- C. territory – habitat – ecosystem – biosphere
- D. habitat – territory – ecosystem – biosphere
- E. biosphere – territory - habitat – ecosystem

84. Which of the following would you expect to be absent, or very rare, on acid soils, deficient in calcium?

- A. protozoans
- B. snails
- C. insects
- D. calcifuge plants
- E. mosses

85. The life cycle of the Large Blue butterfly depends on a species of red ant, *Myrmica sabuleti*. The ants, acting on a chemical secretion similar to that produced by their own grubs, place the Large Blue caterpillar in their brood chambers, where it feeds voraciously on ant grubs. The relationship between butterfly and ant is described as:

- A. mutualism
- B. parasitism
- C. altruism
- D. commensalism
- E. competition

86. Which of the following animal taxa only occur in the sea?

- 1 Starfish and sea urchins (*Stellaroidea, Echinoidea*)
- 2 Jellyfish (*Cnidaria*)
- 3 Sponges (*Calcarea and Silicea*)
- 4 Squids (*Cephalopoda*)
- 5 Highly developed crustacea (*Malacostraca – Crustacea, Astacus*)

- A. 1 and 4
- B. 2 and 3
- C. only 5
- D. 1, 2 and 3
- E. 2, 4 and 5

87. Which of the following is a feature of both fungi and bacteria?

- A. The absence of a cell wall.
- B. Ability of some species to undertake photosynthesis.
- C. Ability of some species to fix nitrogen.
- D. The absence of internal membrane bound organelles such as mitochondria.
- E. Ability of some species to form symbiotic relationships with plants.

88. Two organisms, A and B are from the same order but from different families. Therefore organisms A and B belong to :

- A. the same genus.
- B. different phyla.
- C. the same species.
- D. the same class.
- E. different kingdoms.

89. In the life cycle of the malarial parasite (Plasmodium), which of the following stages might be found in a human host?

- A. Sporozoite
- B. Trophozoite and merozoite
- C. Trophozoite, merozoite and gametocyte
- D. Zygote and gametocyte
- E. Zygote

90. The females of sharks, lizards, snakes and some insects, which retain yolk-filled eggs within the female reproductive tract for considerable periods, are described as:

- A. oviparous
- B. viviparous
- C. ovoviviparous
- D. parthenogenetic
- E. microlecithal